



## Premium Hydraulic Guillotines

**Premium 1 year warranty included**

**METAL CUTTING SYSTEM**

Premium 1 year warranty included

# Guillotines

## Industrial Series



Our range of Premium Hydraulic Guillotines have been in development for many years. This well-built premium **hydraulic guillotine range** can process **up-to 20mm** in thickness.

With a large range of sizes to cater for most standard sheet sizes and applications, we have a guillotine that will suit your business needs. Used in an array of industries such as:

**Aerospace | Automotive | Sign Making | Fabrication | Prototyping**

**“High quality build and an excellent feature set, this premium work Horse is an excellent choice”.**



## Hydraulic - Standard Features & Equipment

CE certified + side fences & Top fence with Opto-Electrical Guards

One off 1.0M Ruled Squaring Arm with tilting stop

two off 1.0M Front Support Arms with tilting stop

one off 1.0M Ruled Front Support Arm with tilting stop

Tiltable Front Finger Guard

Bed infill plates with ball transfers

Hand Moveable Foot Pedal control including emergency stop

Rapid and precise blade clearance adjustment by single handle on the side frame

Fixed cutting angle

Hydraulic and Electrical overload protection

Cutting line illumination

Bed infill plates with ball transfers

E2IS Control: Programmable multiple steps can save up to 40 Programs 25 steps per program | One Key backup/restore facility | Holding, decompression time settings | Stock Counter | One side positioning Retract facility

Opto-electrical Rear Guards, Electric Footswitch, Manuals, 400V/3PH/50h

# Guillotine Control



## E21S Controller features

Programmable multiple steps

Can save up to 40 Programs 25 steps per program

One Key backup/restore facility

Holding / decompression time settings

Stock Counter

One side positioning

Retract facility

Swing Beam Action

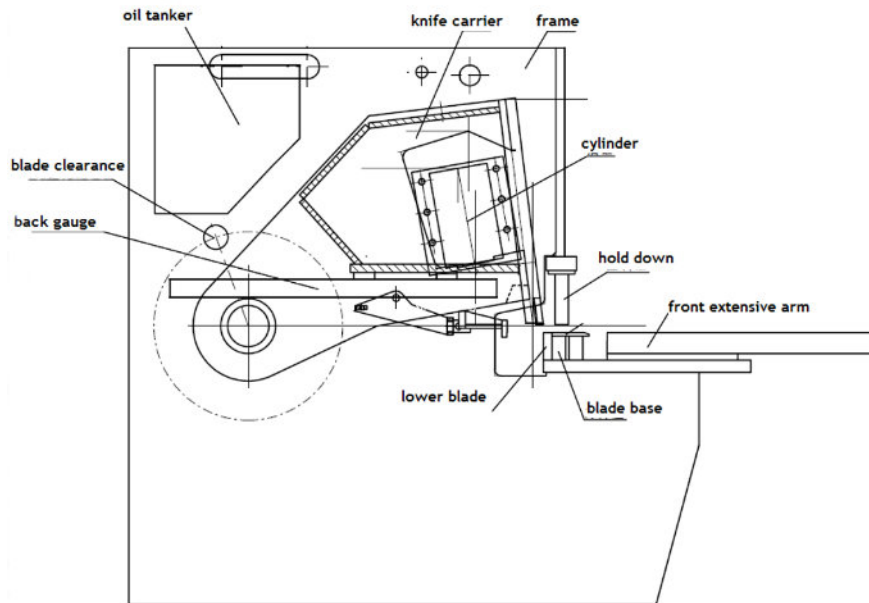

**Efficient**

**Build quality**

**Reduced wear**

The swingbeam action using over dimensional roller bearings at the pivots, guarantees the precision of the blade gap setting. Further adjustments due to wear, as with slideway-guided machines are eliminated. The pivot roller bearing will more than last the life of the machine.

The position of the sturdily designed back-stop, once selected, remains unchanged even during continuous operation. The geometrical relationship of the back-stop to the upper blade frees the plate at the instant of shearing. At the end of its reverse stroke the back-stop swings upwards to allow longer sheets to be cut.

To compensate for the extra blade wear on the bottom blade, due to continual sliding of materials, the bottom blade was designed with four cutting edges, whilst the top blade has two cutting edges.

**Swing-up Back Gauge Benefits**

Optimum Quality of Cut

A fixed angle minimises the distortion when cutting

Precision guidance of the beam

Reliability due to fewer moving parts

Minimum maintenance required

No slideways to grease and adjust, therefore less wear

Clearance for the free fall of materials cut

Complete rigidity under extreme load



## Hydraulic Guillotine Model &amp; Operational Data

Model	Max. Shearing Thickness (mm)	Max. Shearing Width (mm)	Shearing Angle (°)	Number of stroke (mm)	Back gauge range (mm)	Motor power (kW)	Net weight (kg)	Dimensions (L*W*H)
QC12Y-4X2000	4	2000	1°30′	22	20-480	4	3200	2630*2030*1600
QC12Y-4X2500	4	2500	1°30′	20	20-480	4	3800	3130*2030*1600
QC12Y-4X3200	4	3200	1°30′	20	20-600	5.5	5600	3840*2175*1600
QC12Y-4X4000	4	4000	1°30′	18	20-600	5.5	7000	4640*2320*1600
QC12Y-6X2500	6	2500	1°30′	18	20-600	7.5	5200	3130*2320*1600
QC12Y-6X3200	6	3200	1°30′	16	20-600	7.5	6500	3840*2320*1620
QC12Y-6X4000	6	4000	1°30′	14	20-600	7.5	8500	4630*2495*1700
QC12Y-6X6000	6	6000	1°30′	6	20-600	11	16800	6645*2530*2250
QC12Y-8X2500	8	2500	1°30′	14	20-600	11	6200	3140*2345*1620
QC12Y-8X3200	8	3200	1°30′	12	20-600	11	7300	3850*2345*1620
QC12Y-8X4000	8	4000	1°30′	10	20-600	1	9600	4630*2495*1700
QC12Y-8X6000	8	6000	1°30′	6	20-900	15	17600	6650*2845*1700
QC12Y-12X2500	12	2500	1°30′	12	20-900	18.5	9600	3235*3050*2100
QC12Y-12X3200	12	3200	1°30′	10	20-900	18.5	12000	3945*3050*2100
QC12Y-12X4000	12	4000	1°30′	8	20-900	18.5	14500	4745*3210*2200
QC12Y-12X6000	12	6000	1°30′	5	20-900	22	29500	6745*3430*2300
QC12Y-16X2500	16	2500	2°	12	20-900	22	11600	3410*3230*2230
QC12Y-16X3200	16	3200	2°	10	20-900	22	14000	4120*3230*2230
QC12Y-16X4000	16	4000	2°	8	20-900	22	18000	4920*3330*2700
QC12Y-16X6000	16	6000	2°	6	20-900	37	43000	7100*3530*2700
QC12Y-20X2500	20	2500	2°30′	10	20-900	37	17500	3420*3330*2700
QC12Y-20X3200	20	3200	2°30′	8	20-900	37	25500	4180*3330*2700
QC12Y-20X4000	20	4000	2°30′	6	20-900	37	29000	4980*3480*2830
QC12Y-20X6000	20	6000	2°30′	4	20-900	75	56500	7180*3580*2830
QC12Y-25X2500	25	2500	2°30′	8	20-900	45	24000	3480*3430*2700
QC12Y-25X3200	25	3200	2°30′	8	20-900	45	32000	4180*3430*2700
QC12Y-25X4000	25	4000	2°30′	6	20-900	45	39500	4980*3580*2800
QC12Y-32X2500	32	2500	3°	6	20-900	55	33000	3760*4405*3150
QC12Y-32X3200	32	3200	3°	6	20-900	55	40500	4590*4405*3150

Contact one of our sheet metal machinery experts today

**Tel: 0121 541 1444**

Premium 1 year warranty included

# Guillotines

Contact one of our sheet metal machinery experts today

**Tel: 0121 541 1444**

